

MANUAL

Professional Line | PROTECTION TECHNOLOGY
MADE SIMPLE

XR1 | ROTOR EARTH FAULT RELAY



ROTOR EARTH FAULT RELAY

Original document

English

Revision: D

**SEG Electronics reserves the right to update any portion of this publication at any time.
Information provided by SEG Electronics is believed to be correct and reliable.
However, no responsibility is assumed by SEG Electronics unless otherwise expressly undertaken.**

© SEG Electronics 1994–2020. All rights reserved.

Content

1.	Applications and Features	4
2.	Design	5
3.	Function.....	6
4.	Operation and Settings.....	8
4.1	Setting of DIP-Switches	9
4.2	Setting of the Tripping Values.....	10
4.3	Communication via Serial Interface Adapter XRS1	11
5.	Relay Case and Technical Data	12
5.1	Relay Case.....	12
5.2	Technical Data	13

1. Applications and Features

Protection relay XR1 of our PROFESSIONAL LINE is used for detection of rotor earth faults in synchronous machines. The earth fault element detects high and low impedance earth faults in rotor windings and is in two stage design (for alarm and trip).

When compared to the conventional protection equipment all relays of the PROFESSIONAL LINE reflect the superiority of digital protection techniques with the following features:

- High measuring accuracy by digital data processing
- Fault indication via LEDs
- Extremely wide operating ranges of the supply volt-age by universal wide-range power supply
- Very fine graded wide setting ranges
- Data exchange with process management system by serial interface adapter XRS1 which can be retrofitted
- Extremely short response time
- Compact design by SMD-technology

In addition to this, relay XR1 has the following special features:

- Detection of high impedance earth faults in rotor windings and is in two stage design.
- Short circuit and overvoltage proof measuring input for earth fault protection
- Separately setting of trip delay for R< and R<<

2. Design

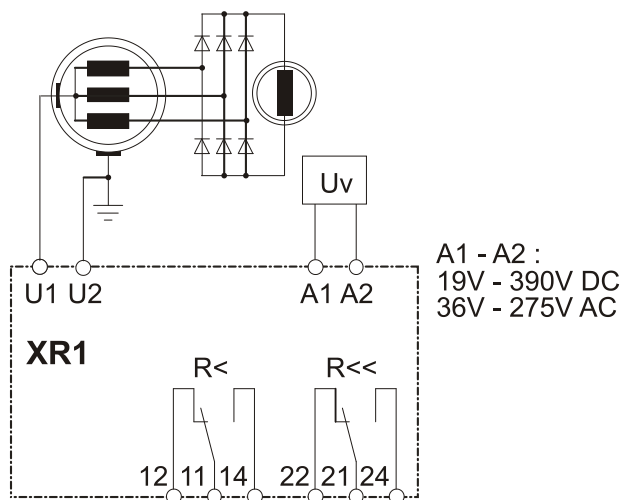

Figure 2.1: Connections

Measuring paths

By using a measuring voltage, the protection relay ascertains the resistance of the test object via terminals U1 and U2.

Auxiliary voltage supply

Unit XR1 needs a separate auxiliary voltage supply. Therefore a dc or ac voltage must be used. Unit XR1 has an integrated wide range power supply. Voltages in the range from 19 - 390 Vdc or 36 - 275 Vac can be applied at connection terminals A1 and A2.

Contact positions

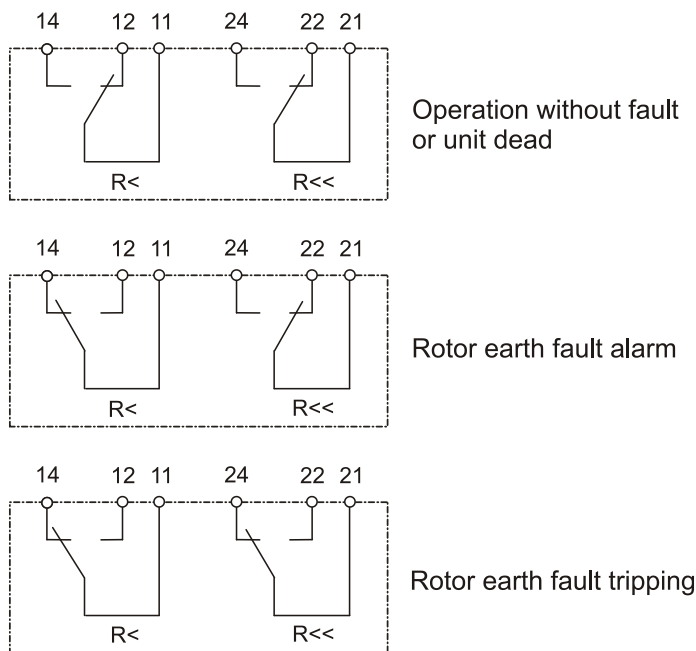

Figure 2.2: Contact positions of the output relays

3. Function

A single earth fault on the field windings of a synchronous generator produces no immediate damaging effect. It must be detected and removed because of the possibility of a second earth fault that could short a part of the field winding and cause severe damage. XR1 provides an alarm and a trip element for the rotor earth fault protection.

The insulation resistance measurement system of the XR1 can be used for synchronous generators of both types, with and without brushes. It works with a low frequency alternating test voltage (1 Hz, $\pm 24\text{V}$) which is connected via slip rings to the main exciter winding and to rotor earth (ref. to connection diagram).

The low frequency of the test voltage is used to avoid malfunction due to the field-to-earth capacitance (C_E) which can reach values up to $1\ \mu\text{F}$ on large generators. Within the device, there is a current limiting resistor (R_V) to prevent overcurrent in case of a fault. After all, the device measures the voltage at an (internal) resistor R_{Meas} , and this voltage is directly related to the earth current to be supervised.

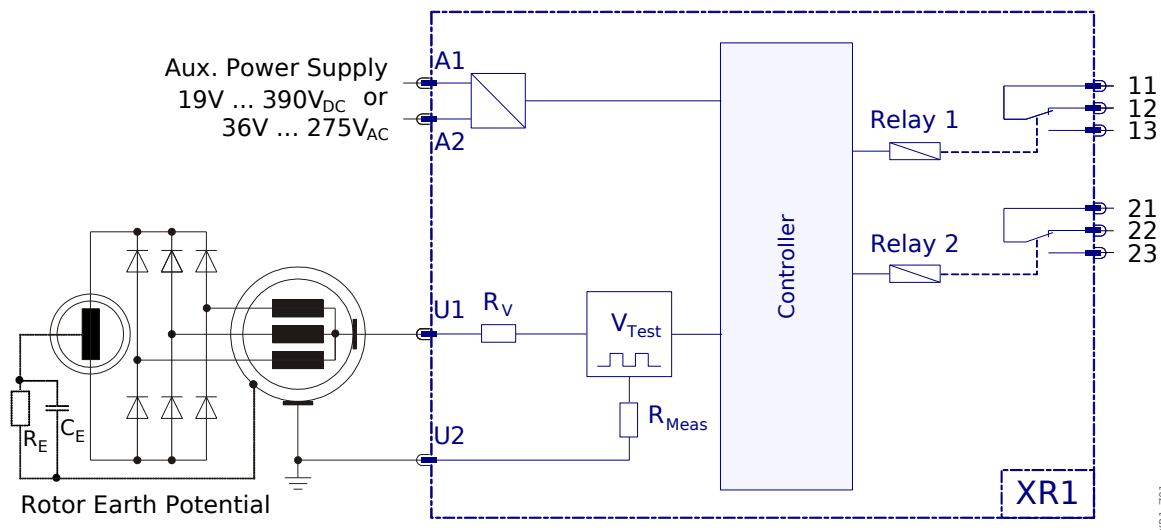

Figure 3.1: Measuring principle of the earth current. C_E and R_E are equivalent circuit symbols for the field-to-earth capacitance and resistance, respectively.

The insulation resistance measurement is based on the subsequent measurement of the shunt resistor voltage of two consecutive half cycles, i.e. positive and negative test voltage. From the differential voltage between the positive and negative measuring voltage at the end of each half cycle the insulation resistance is calculated. This way wrong measurement due to the earth capacitance and possible voltage offsets is avoided.

Figure 3.2 explains the measuring principle:

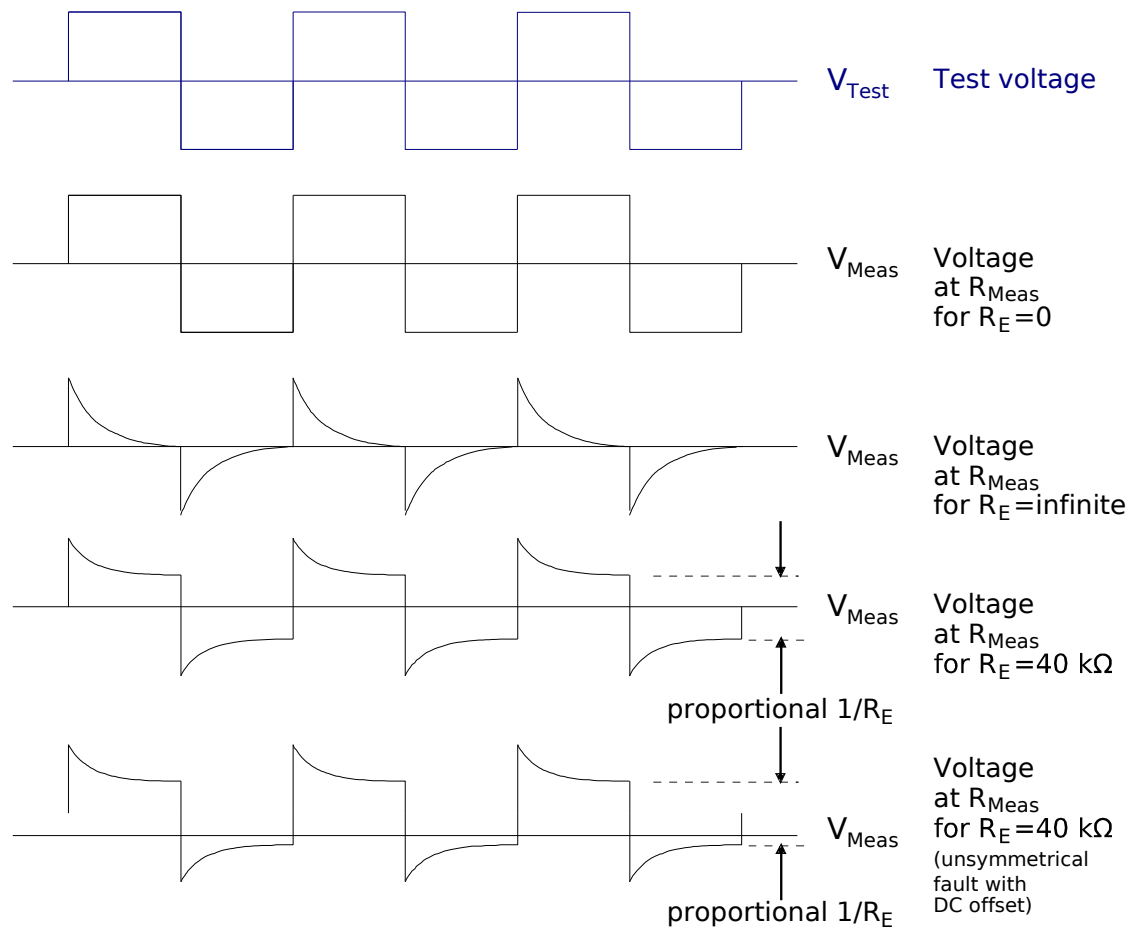

Figure 3.2: Measuring principle

XR1_Z02

4. Operation and Settings

All operating elements needed for setting parameters are located on the front plate of the XR1 as well as all display elements.

Because of this all adjustments of the unit can be made or changed without disconnecting the unit off the DIN-rail.

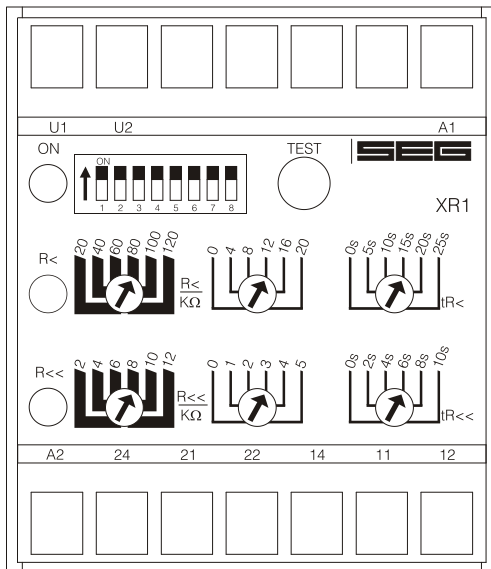

Figure 4.1: Front plate

For adjustment of the unit the transparent cover has to be opened as illustrated. Do not use force! The transparent cover has two inserts for labels.

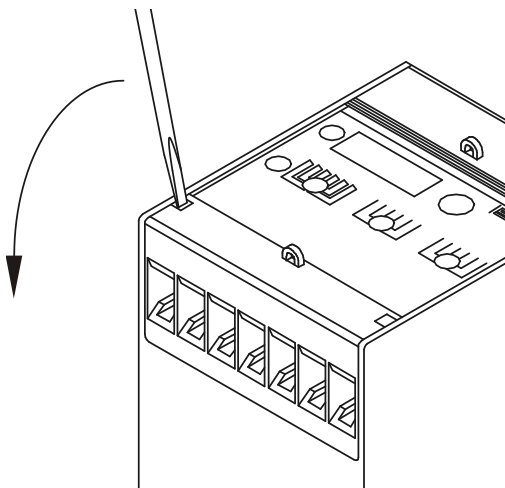

Figure 4.2: How to open the transparent cover

LEDs

LED "ON" is used for display of the readiness for service (at applied auxiliary voltage U_v). LED R< and R<< signal pickup (flashing) or tripping (steady light) of the corresponding function.

Test push button

This push button is used for test tripping of the unit and when pressed for 5 s a check-up of the hardware takes place. Both output relays are tripped and all tripping LEDs light up.

4.1 Setting of DIP-Switches

The DIP-switch block on the front plate of the XR1 is used for adjustment of the nominal values and setting of function parameters:

DIP-switch	OFF	ON	Function
1			
2			
3			
4	active	blocked	Rotor earth fault warning
5	active	blocked	Rotor earth fault tripping
6			
7	x1	x2	Multiplier for $tR<$
8	x1	x2	Multiplier for $tR<<$

Table 4.1: Functions of DIP-switches

Blocking of rotor earth fault warning element

When DIP-switch 4 is in "ON" position, the rotor earth fault warning element is blocked.

Blocking of rotor earth fault trip element

When DIP-switch 5 is in "ON" position, the rotor earth fault trip element is blocked.

4.2 Setting of the Tripping Values

The PROFESSIONAL LINE units have the unique possibility of high accuracy fine adjustments. For this, two potentiometers are used. The coarse setting potentiometer can be set in discrete steps of 20 k Ω or 5 k Ω . A second fine adjustment potentiometer is then used for continuously variable setting of the final (0 - 20 k Ω or 0 - 5 k Ω). Adding of the two values results in the precise tripping value.

Rotor earth fault alarm R<

The rotor earth fault alarm can be set in the range from 20 - 140 k Ω with the aid of the potentiometer illustrated on the following diagram.

Example:

A tripping value of 92 k Ω is to be set. The set value of the right potentiometer is just added to the value of the coarse setting potentiometer. (The arrow of the coarse setting potentiometer must be inside of the marked bar, otherwise no defined setting value).

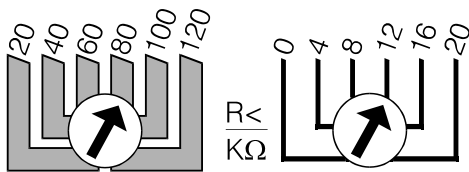

Figure 4.3: Adjustment example

Rotor earth fault tripping R<<

The rotor earth fault tripping can be set in the range from 0 - 30 k Ω with the aid of the potentiometer illustrated on the following diagram (R<< min = 2 k Ω)

Example:

A tripping value of 18 k Ω is to be set.

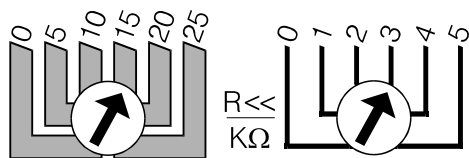

Figure 4.4: Adjustment example

Time delay tR<

With the aid of DIP-switch 7 the time delay at rotor earth fault alarm tR< can be adjusted continuously variable in the range from 0 - 25 s or 0 - 50 s.

Time delay tR<<

With the aid of DIP-switch 8 the time delay at rotor earth fault tripping tR<< can be adjusted continuously variable in the range from 0 - 10 s or 0 - 20 s.

4.3 Communication via Serial Interface Adapter XRS1

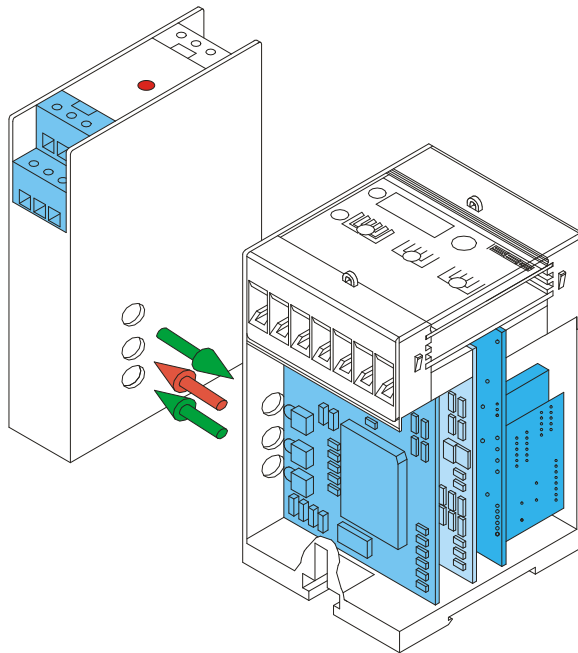

Figure 4.5: Communication principle

For communication of the units among each other and with a superior management system, the interface adapter XRS1 is available for data transmission, including operating software for our relays. This adapter can easily be retrofitted at the side of relay. Screw terminals simplify its installation. Optical transmission of this adapter makes galvanic isolation of the relay possible. Aided by the software, actual measured values can be processed, relay parameters set and protection functions programmed at the output relays. Information about unit XRS1 in detail can be taken from the description of this unit.

5. Relay Case and Technical Data

5.1 Relay Case

Relay XR1 is designed to be fastened onto a DIN-rail acc. to DIN EN 50022, the same as all units of the PROFESSIONAL LINE. The front plate of the relay is protected with a sealable transparent cover (IP40).

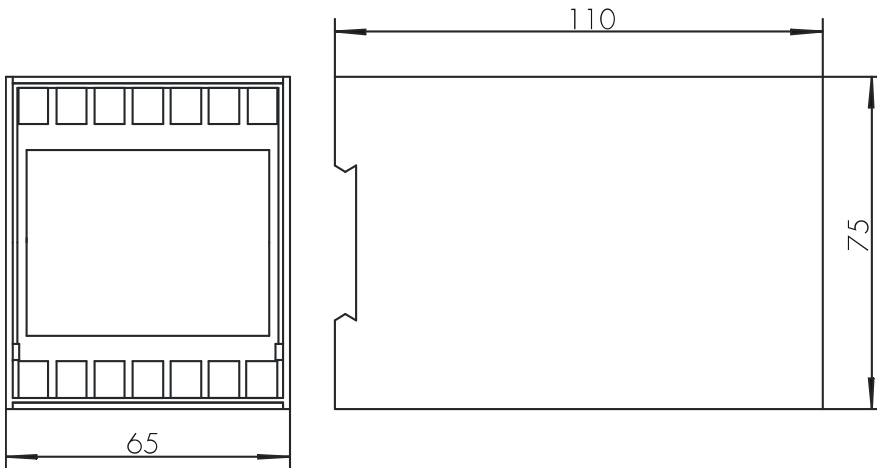

Figure 5.1: Dimensional drawing. (All dimensions in millimeters.)

Connection terminals

The connection of up to a maximum $2 \times 2.5 \text{ mm}^2$ cross-section conductors is possible. For this the transparent cover of the unit has to be removed (see chapter 4).

5.2 Technical Data

Measuring input circuits

Thermal withstand capability
in measuring circuit:

during 10 s $U_{max} = 600 \text{ V}$
continuous $U_{max} = 140 \text{ VAC/DC}$

Output voltage of
measuring circuit:

$U_H = \pm 24 \text{ V}$ (short circuit proof)
 $f_H = 1 \text{ Hz}$

Auxiliary voltage
Rated auxiliary voltage U_v /
Power consumption:

19 - 390 V DC or 36 - 275 V AC ($f = 40 - 70 \text{ Hz}$)/
4 W (terminals A1 and A2)

Maximum permissible interruption
time of aux. voltage:

$U_v = 24 \text{ Vdc}$: $t_u = 8 \text{ ms}$, $UV = 48 \text{ V DC}$: $t_u = 35 \text{ ms}$
 $U_v > 60 \text{ Vdc}$: $t_u = 50 \text{ ms}$

Common data

Dropout to pickup ratio: 10 %
Resetting time from pickup: <1 s
Returning time from trip: 500 ms
Minimum initialization time after
supply voltage has applied: 1.1 s
Minimum response time
when supply voltage is available: 1 s

Output relay

Number of relays: 2
Contacts: 1 changeover contact for each trip relay
Maximum breaking capacity: ohmic 1250 VA/AC resp. 120 W/DC
inductive 500VA/AC resp. 75 W/DC
Maximum rated voltage: 250 V AC
220 V DC ohmic load $I_{max} = 0,2 \text{ A}$
24 V DC inductive load $I_{max} = 0,1 \text{ A}$ at $L/R \leq 50 \text{ ms}$
inductive load $I_{max} = 5 \text{ A}$
Minimum load: 1 W / 1 VA bei $U_{min} \leq 10$
Maximum rated current: 5 A
Making current (16ms): 20 A
Contact life span: 10^5 operations at max. breaking capacity
Contact material: AgCdO

System data

Design standard: VDE 0435 T303; IEC 0801 part 1-4;
VDE 0160; IEC 255-4; BS142; VDE 0871
Temperature range at storage
and operation: - 25°C to + 70°C
Constant climate class F
acc. DIN 40040 and
DIN IEC 68, part 2-3: more than 56 days at 40°C and 95 % relative humidity

High voltage test acc. to VDE 0435, part 303

Voltage test: 2.5 kV (eff.)/50 Hz; 1 min
Surge voltage test: 5 kV; 1.2/50 μs , 0.5 J
High frequency test: 2.5 kV/1 MHz

Electrostatic discharge (ESD)
acc. to IEC 0801, part 2:

8 kV

Radiated electromagnetic field test acc. to IEC 0801, part 3:	10 V/m
Electrical fast transient (burst) acc. to IEC 0801, part 4:	4 kV/2.5kHz, 15 ms
Radio interference suppression test as per DIN 57871 and VDE 0871:	limit value class A
Accuracy of the specific rated values:	5 % or ± 2 k Ω Repeat accuracy: 5 %
Basic time delay accuracy:	3 % or ± 100 ms 3 % or $+0...2.2$ s (R-measuring)
Temperature effect:	0.1 % per K
Mechanical test:	
Shock:	class 1 acc. to DIN IEC 255-21-2
Vibration:	class 1 acc. to DIN IEC 255-21-1
Degree of protection	
Front plate:	IP40 at closed front cover
Weight:	approx. 0.5 kg
Mounting position:	any
Relay case material:	self-extinguishing

Parameter	Setting range	Graduation
R<	20 - 140 k Ω	continuously
R<<	0 - 30 k Ω	continuously
tR<	0 - 25 s / 0 - 50 s	continuously
tR<<	0 - 10 s / 0 - 20 s	continuously

Table 5.1: Setting ranges and graduation

Technical data subject to change without notice!

Setting-list XR1

Project: _____ SEG job.-no.: _____

Function group: = _____ Location: + _____ Relay code: - _____

Relay functions: _____ Date: _____

Setting of parameters

Function		Unit	Default settings	Actual settings
R<	Rotor earth fault alarm	k Ω	20	
R<<	Rotor earth fault tripping	k Ω	2	
tR<	Time delay for R<	s	0	
tR<<	Time delay for R<<	s	0	

DIP-switch setting

DIP-switch	Function	Default settings	Actual settings
1			
2			
3			
4	Rotor earth fault alarm	Active	
5	Rotor earth fault tripping	Active	
6			
7	Multiplier for tR<	x1	
8	Multiplier for tR<<	x1	

Professional Line

<https://docs.SEGelectronics.de/xr1>

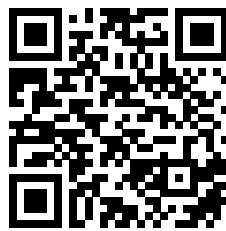

SEG Electronics GmbH reserves the right to update any portion of this publication at any time. Information provided by SEG Electronics GmbH is believed to be correct and reliable. However, SEG Electronics GmbH assumes no responsibility unless otherwise expressly undertaken.



SEG Electronics GmbH
Krefelder Weg 47 • D-47906 Kempen (Germany)
Postfach 10 07 55 (P.O.Box) • D-47884 Kempen (Germany)
Telephone: +49 (0) 21 52 145 1

Internet: www.SEGelectronics.de

Sales
Telephone: +49 (0) 21 52 145 331
Fax: +49 (0) 21 52 145 354
E-mail: info@SEGelectronics.de

Service
Telephone: +49 (0) 21 52 145 614
Fax: +49 (0) 21 52 145 354
E-mail: info@SEGelectronics.de

SEG Electronics has company-owned plants, subsidiaries, and branches, as well as authorized distributors and other authorized service and sales facilities throughout the world.

Complete address / phone / fax / email information for all locations is available on our website.